

**Series**

**TERMOSER  
STR**

**Thermogenerators on wheels  
with warm air outlets from bottom**



**CE**

**Quality  
products**

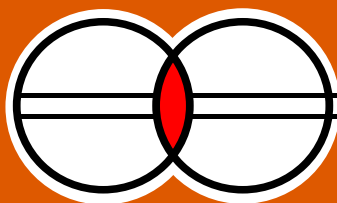

**TERMOTECNICA®  
PERICOLI**

# Characteristics of TERMOSER STR

The air heaters of the **TERMOSER** series type **STR** were designed and developed to satisfy the particular need of users in agriculture who require an efficient distribution of warm air on the ground. **STR** air heaters are composed essentially of the heat exchanger at high efficiency.

The combustion chamber is made in **AISI 430** stainless steel of high chromium contents: depending on models, there is one or there are two centrifugal fans in the top part of the heater of high air displacement.

A **Kloekner-Moeller** controlbox is standard for a reliable automatic functioning.

The bodywork is made around a frame structure and is in aluminised steel sheet and painted steel panels, all insulated. Heavy-duty large diameter wheels and moving handle make it easy to move the heater from one room to another.

Two ductable warm air outlets in front and rear, placed in the bottom part of the machine, stand for uniform distribution of the air.

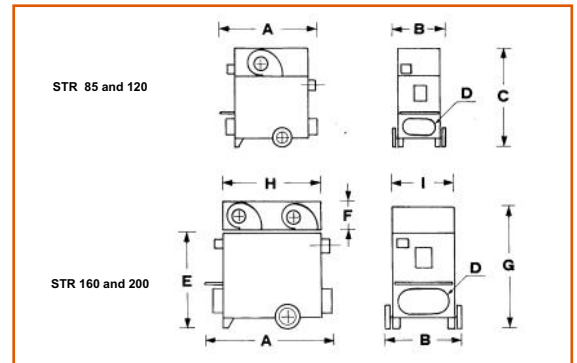
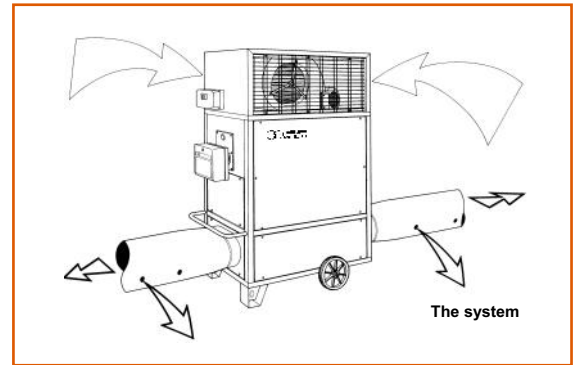

*Approved by the Swiss and Swedish Authorities*

## A removable cover plate on the heat exchanger is of utmost importance:

In order to keep your heater of highest efficiency, it must be cleaned profoundly as often as appears necessary, but at least once a year.

The building up of soot and combustion residues inside the heat exchanger would form an insulating crust gradually and with that a constant reduction of efficiency over the lifespan of the heater. The presence of a removable coverplate on the heat exchanger allows a proper and easy cleaning.

## Technical features:

MODEL	Thermic power		Consumption		Performance	Air displ.	Fan power	External dimensions (mm.)									Chimney Ø		Weights (kg.)	
	Kcal/h	kW	OIL kg/h	GAS mtc/h				%	mtc/h	kW	A	B	C	D	E	F	G	H	I	mm.
<b>TERMOSER STR 85</b>	85000	99	8,3	9,900	89	8000	1,50	1530	850	1930	2X400	---	---	---	---	---	180	---	---	296
<b>TERMOSER STR 120</b>	120000	140	12,4	14,900	89	11000	2,20	1650	970	2160	2X500	---	---	---	---	---	200	---	---	365
<b>TERMOSER STR 160</b>	160000	186	16,6	19,900	89	15000	3,00	1740	1110	---	2X600	1990	500	2350	1400	920	250	342	115	457
<b>TERMOSER STR 200</b>	200000	233	20,1	24,100	89	18000	4,00	1900	1230	---	2X700	2060	580	2590	1550	1040	250	416	150	566

All indications in this catalogue are without engagement. In a constant effort to improve our products, specifications may change.



**TERMOTECNICA PERICOLI SRL.**  
P.o. box 262  
17030 Albenga (SV), Italy  
Tel. +39 0182 589006  
Fax +39 0182 589005  
[www.pericoli.com](http://www.pericoli.com)  
[termotecnica@pericoli.com](mailto:termotecnica@pericoli.com)